

Menu ▾ | **Home** | **Insert** | **Comment** | **Edit** | **Page** | **Protect** | **Tools** | Click to search

**Hand Tool** | **Edit Text** | **Edit Picture** | **Screen Grab** | **PDF to Word** | **PDF to Picture** | **Zoom Out** |  | **Zoom In** | **Clockwise** | **Anticlockwise** | **Previous**

Thumbnail

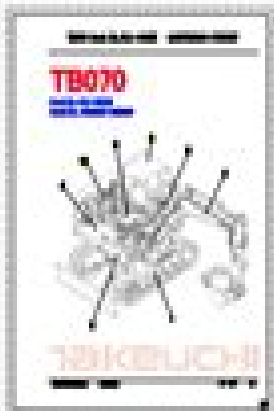

1

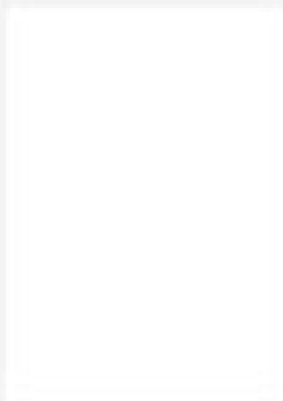

2



TB070 Book No. PL1-10125 E/91700004-1705487

# TB070

Book No. PL1-10125  
Serial No. 1700004-1705487

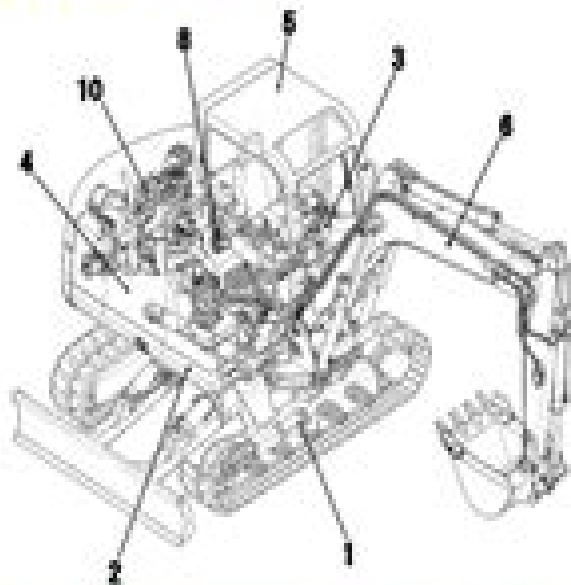

# TAKEUCHI

# Takeuchi Tb070 Compact Excavator Parts Manual

**Caterpillar Inc. Peoria, Ill..**



**Takeuchi Tb070 Compact Excavator Parts Manual:**

*Parts Manual* Caterpillar Inc. Peoria, Ill.,1996      Parts Manual Caterpillar Inc. Peoria, Ill.,1995      **Parts Manual**  
Caterpillar Inc. Peoria, Ill.,1993      *Parts Manual* Caterpillar Inc. Peoria, Ill.,1990      **Parts Manual** Caterpillar Inc.  
Peoria, Ill.,1993      **Parts Manual** Caterpillar Inc. Peoria, Ill.,1992      *Parts Manual* Caterpillar Inc. Peoria, Ill.,1995  
Parts Manual Caterpillar Inc. Peoria, Ill.,1994      *Parts Manual* Caterpillar Inc. Peoria, Ill.,1993      **Parts Manual**  
Caterpillar Inc. Peoria, Ill.,1995      **Parts Manual** Caterpillar Inc. Peoria, Ill.,1994      Parts Manual Caterpillar Inc.  
Peoria, Ill.,1994      **Parts Manual** Caterpillar Inc. Peoria, Ill.,1992      Parts Manual Caterpillar Inc. Peoria, Ill.,1996  
**Parts Manual** Caterpillar Inc. Peoria, Ill.,1998      **Parts Manual** Caterpillar Inc. Peoria, Ill.,1995      **Master Parts**  
**Manual** Tecumseh Products Company. Engine and Gear Service Division,1982

Delve into the emotional tapestry woven by in **Takeuchi Tb070 Compact Excavator Parts Manual** . This ebook, available for download in a PDF format ( \*), is more than just words on a page; itis a journey of connection and profound emotion. Immerse yourself in narratives that tug at your heartstrings. Download now to experience the pulse of each page and let your emotions run wild.

[https://recruitmentslovakia.com/data/detail/Documents/nature\\_trail\\_games\\_kids.pdf](https://recruitmentslovakia.com/data/detail/Documents/nature_trail_games_kids.pdf)

## **Table of Contents Takeuchi Tb070 Compact Excavator Parts Manual**

1. Understanding the eBook Takeuchi Tb070 Compact Excavator Parts Manual
  - The Rise of Digital Reading Takeuchi Tb070 Compact Excavator Parts Manual
  - Advantages of eBooks Over Traditional Books
2. Identifying Takeuchi Tb070 Compact Excavator Parts Manual
  - Exploring Different Genres
  - Considering Fiction vs. Non-Fiction
  - Determining Your Reading Goals
3. Choosing the Right eBook Platform
  - Popular eBook Platforms
  - Features to Look for in an Takeuchi Tb070 Compact Excavator Parts Manual
  - User-Friendly Interface
4. Exploring eBook Recommendations from Takeuchi Tb070 Compact Excavator Parts Manual
  - Personalized Recommendations
  - Takeuchi Tb070 Compact Excavator Parts Manual User Reviews and Ratings
  - Takeuchi Tb070 Compact Excavator Parts Manual and Bestseller Lists
5. Accessing Takeuchi Tb070 Compact Excavator Parts Manual Free and Paid eBooks
  - Takeuchi Tb070 Compact Excavator Parts Manual Public Domain eBooks
  - Takeuchi Tb070 Compact Excavator Parts Manual eBook Subscription Services
  - Takeuchi Tb070 Compact Excavator Parts Manual Budget-Friendly Options

6. Navigating Takeuchi Tb070 Compact Excavator Parts Manual eBook Formats
  - ePub, PDF, MOBI, and More
  - Takeuchi Tb070 Compact Excavator Parts Manual Compatibility with Devices
  - Takeuchi Tb070 Compact Excavator Parts Manual Enhanced eBook Features
7. Enhancing Your Reading Experience
  - Adjustable Fonts and Text Sizes of Takeuchi Tb070 Compact Excavator Parts Manual
  - Highlighting and Note-Taking Takeuchi Tb070 Compact Excavator Parts Manual
  - Interactive Elements Takeuchi Tb070 Compact Excavator Parts Manual
8. Staying Engaged with Takeuchi Tb070 Compact Excavator Parts Manual
  - Joining Online Reading Communities
  - Participating in Virtual Book Clubs
  - Following Authors and Publishers Takeuchi Tb070 Compact Excavator Parts Manual
9. Balancing eBooks and Physical Books Takeuchi Tb070 Compact Excavator Parts Manual
  - Benefits of a Digital Library
  - Creating a Diverse Reading Collection Takeuchi Tb070 Compact Excavator Parts Manual
10. Overcoming Reading Challenges
  - Dealing with Digital Eye Strain
  - Minimizing Distractions
  - Managing Screen Time
11. Cultivating a Reading Routine Takeuchi Tb070 Compact Excavator Parts Manual
  - Setting Reading Goals Takeuchi Tb070 Compact Excavator Parts Manual
  - Carving Out Dedicated Reading Time
12. Sourcing Reliable Information of Takeuchi Tb070 Compact Excavator Parts Manual
  - Fact-Checking eBook Content of Takeuchi Tb070 Compact Excavator Parts Manual
  - Distinguishing Credible Sources
13. Promoting Lifelong Learning
  - Utilizing eBooks for Skill Development
  - Exploring Educational eBooks
14. Embracing eBook Trends
  - Integration of Multimedia Elements

- Interactive and Gamified eBooks

## **Takeuchi Tb070 Compact Excavator Parts Manual Introduction**

Free PDF Books and Manuals for Download: Unlocking Knowledge at Your Fingertips In today's fast-paced digital age, obtaining valuable knowledge has become easier than ever. Thanks to the internet, a vast array of books and manuals are now available for free download in PDF format. Whether you are a student, professional, or simply an avid reader, this treasure trove of downloadable resources offers a wealth of information, conveniently accessible anytime, anywhere. The advent of online libraries and platforms dedicated to sharing knowledge has revolutionized the way we consume information. No longer confined to physical libraries or bookstores, readers can now access an extensive collection of digital books and manuals with just a few clicks. These resources, available in PDF, Microsoft Word, and PowerPoint formats, cater to a wide range of interests, including literature, technology, science, history, and much more. One notable platform where you can explore and download free Takeuchi Tb070 Compact Excavator Parts Manual PDF books and manuals is the internet's largest free library. Hosted online, this catalog compiles a vast assortment of documents, making it a veritable goldmine of knowledge. With its easy-to-use website interface and customizable PDF generator, this platform offers a user-friendly experience, allowing individuals to effortlessly navigate and access the information they seek. The availability of free PDF books and manuals on this platform demonstrates its commitment to democratizing education and empowering individuals with the tools needed to succeed in their chosen fields. It allows anyone, regardless of their background or financial limitations, to expand their horizons and gain insights from experts in various disciplines. One of the most significant advantages of downloading PDF books and manuals lies in their portability. Unlike physical copies, digital books can be stored and carried on a single device, such as a tablet or smartphone, saving valuable space and weight. This convenience makes it possible for readers to have their entire library at their fingertips, whether they are commuting, traveling, or simply enjoying a lazy afternoon at home. Additionally, digital files are easily searchable, enabling readers to locate specific information within seconds. With a few keystrokes, users can search for keywords, topics, or phrases, making research and finding relevant information a breeze. This efficiency saves time and effort, streamlining the learning process and allowing individuals to focus on extracting the information they need. Furthermore, the availability of free PDF books and manuals fosters a culture of continuous learning. By removing financial barriers, more people can access educational resources and pursue lifelong learning, contributing to personal growth and professional development. This democratization of knowledge promotes intellectual curiosity and empowers individuals to become lifelong learners, promoting progress and innovation in various fields. It is worth noting that while accessing free Takeuchi Tb070 Compact Excavator Parts Manual PDF books and manuals is convenient and cost-effective, it is vital to respect copyright laws and intellectual property rights. Platforms

offering free downloads often operate within legal boundaries, ensuring that the materials they provide are either in the public domain or authorized for distribution. By adhering to copyright laws, users can enjoy the benefits of free access to knowledge while supporting the authors and publishers who make these resources available. In conclusion, the availability of Takeuchi Tb070 Compact Excavator Parts Manual free PDF books and manuals for download has revolutionized the way we access and consume knowledge. With just a few clicks, individuals can explore a vast collection of resources across different disciplines, all free of charge. This accessibility empowers individuals to become lifelong learners, contributing to personal growth, professional development, and the advancement of society as a whole. So why not unlock a world of knowledge today? Start exploring the vast sea of free PDF books and manuals waiting to be discovered right at your fingertips.

### **FAQs About Takeuchi Tb070 Compact Excavator Parts Manual Books**

**What is a Takeuchi Tb070 Compact Excavator Parts Manual PDF?** A PDF (Portable Document Format) is a file format developed by Adobe that preserves the layout and formatting of a document, regardless of the software, hardware, or operating system used to view or print it. **How do I create a Takeuchi Tb070 Compact Excavator Parts Manual PDF?**

There are several ways to create a PDF: Use software like Adobe Acrobat, Microsoft Word, or Google Docs, which often have built-in PDF creation tools. Print to PDF: Many applications and operating systems have a "Print to PDF" option that allows you to save a document as a PDF file instead of printing it on paper. Online converters: There are various online tools that can convert different file types to PDF. **How do I edit a Takeuchi Tb070 Compact Excavator Parts Manual PDF?**

Editing a PDF can be done with software like Adobe Acrobat, which allows direct editing of text, images, and other elements within the PDF. Some free tools, like PDFescape or Smallpdf, also offer basic editing capabilities. **How do I convert a**

**Takeuchi Tb070 Compact Excavator Parts Manual PDF to another file format?** There are multiple ways to convert a PDF to another format: Use online converters like Smallpdf, Zamzar, or Adobe Acrobat's export feature to convert PDFs to formats like Word, Excel, JPEG, etc. Software like Adobe Acrobat, Microsoft Word, or other PDF editors may have options to export or save PDFs in different formats. **How do I password-protect a Takeuchi Tb070 Compact Excavator Parts**

**Manual PDF?** Most PDF editing software allows you to add password protection. In Adobe Acrobat, for instance, you can go to "File" -> "Properties" -> "Security" to set a password to restrict access or editing capabilities. Are there any free alternatives to Adobe Acrobat for working with PDFs? Yes, there are many free alternatives for working with PDFs, such as: LibreOffice: Offers PDF editing features. PDFsam: Allows splitting, merging, and editing PDFs. Foxit Reader: Provides basic PDF viewing and editing capabilities. How do I compress a PDF file? You can use online tools like Smallpdf, ILovePDF, or desktop software like Adobe Acrobat to compress PDF files without significant quality loss. Compression reduces the file size,

making it easier to share and download. Can I fill out forms in a PDF file? Yes, most PDF viewers/editors like Adobe Acrobat, Preview (on Mac), or various online tools allow you to fill out forms in PDF files by selecting text fields and entering information. Are there any restrictions when working with PDFs? Some PDFs might have restrictions set by their creator, such as password protection, editing restrictions, or print restrictions. Breaking these restrictions might require specific software or tools, which may or may not be legal depending on the circumstances and local laws.

**Find Takeuchi Tb070 Compact Excavator Parts Manual :**

[nature trail games kids](#)

[advanced power answer key linda jeffries](#)

[pc training college 2016 application form](#)

[larchitecte et lempereur dabyrie](#)

**manual board computer e53**

[upng 2013 intakes](#)

**2005 hyundai tiburon service manual**

[manuale di napoletanitagrave](#)

**operating manual allison gas turbines**

[operating manual audio 50](#)

**mightier than the sword**

[naughty charades words list](#)

[1997 suburban repair manua](#)

**2004 bmw x3 user manual**

**boeing 777 maintenance manual waste line cleaning**

**Takeuchi Tb070 Compact Excavator Parts Manual :**

**economic crime investigator jobs employment indeed com** - Jan 27 2022

web 182 economic crime investigator jobs available on indeed com apply to investigator intelligence analyst criminal investigator and more

**economic detective colobano** - Aug 02 2022

web economic detective colobano answers custard130 com april 29th 2018 economic detective colobano answers is a book



that has various characteristic with others you

**the economist intelligence unit** - Nov 24 2021

web the surge in tourism that was recorded in 2022 will provide strong momentum in 2023 24 and we believe that the tourism sector will recover fully to pre coronavirus highs by end

**economic detective colobano uniport edu ng** - Feb 25 2022

web of under as competently as review economic detective colobano what you with to read the suspicions of mr whicher kate summerscale 2008 04 15 the dramatic story of the

economic detective colobano uniport edu ng - Apr 29 2022

web apr 14 2023 economic detective colobano 1 8 downloaded from uniport edu ng on april 14 2023 by guest economic detective colobano if you ally craving such a referred

cocaine is set to overtake oil to become colombia s main export - Jul 13 2023

web 1 day ago september 14 2023 at 11 52 am pdt listen 2 28 cocaine is set to become colombia s main export overtaking oil as production of the narcotic continues to

**cocaine to overtake crude oil as colombia s main export after** - Feb 08 2023

web 51 minutes ago bloomberg economics has revealed that cocaine is accelerating to become colombia s main export after generating 18 2 billion as revenue for the south

**research article panel data analysis on the socio** - Jul 01 2022

web gdp positively affect the corruption perception index the rate of inflation gdp and government spending did not have a significant relationship with corruption keywords

*latam daily bcrp rate cut colombia brazil and peru macro* - May 11 2023

web 19 hours ago senior economist strategist the usd is sitting mixed to weaker flat against the mxn and on track for its first weekly scotiabank gbm 44 207 826 5654

**u3a3 adanielsen pdf name anthony danielsen date period 2** - Apr 10 2023

web name date period ch 12 economic detective colobano problem colobano is a small stable country in the western hemisphere its economy is based primarily on the

**swap rates jump as hopes fade of an early colombian interest** - Mar 09 2023

web sep 8 2023 annual inflation slowed to 11 43 in august the statistics agency said thursday above the forecast of all 22 analysts surveyed by bloomberg that s the more

**chapter 12 economic detective pdf namejaydengiuliano 4** - Aug 14 2023

web may 19 2021 name date period ch 12 economic detective colobano problem colobano is a small stable country in the

western hemisphere its economy is based

**panel data analysis on the socio economic determinants of** - Apr 17 2021

web dec 31 2022 ty jour t1 panel data analysis on the socio economic determinants of corruption in the d 8 countries au fatihkarasaç halilkete y1 2022 py 2022 n1

**economicdetectivecolobano rachelstattersall** - Aug 22 2021

web economic detective colobano answers 1 25 downloaded from ads independent com on november 13 2022 by guest economic detective colobano answers recognizing the

economic detective colobano help environment harvard edu - Jan 07 2023

web economic detective colobano this is likewise one of the factors by obtaining the soft documents of this economic detective colobano by online you might not require

**economic detective colobano avenza dev avenza com** - Mar 29 2022

web dec 4 2022 economic detective colobano 2 8 downloaded from avenza dev avenza com on december 4 2022 by guest from renowned scholars in the fields of

*economic detective colobano mail srilankalaw lk* - Jul 21 2021

web economic detective colobano 1 economic detective colobano getting the books economic detective colobano now is not type of challenging means you could not

economic detective colobano ol wise edu jo - May 31 2022

web economic detective colobano 1 economic detective colobano right here we have countless book economic detective colobano and collections to check out we

*read free economic detective colobano willowwoodco com* - Dec 06 2022

web mar 2 2023 economic detective colobano is available in our digital library an online access to it is set as public so you can get it instantly our digital library hosts in multiple















*the economics detective youtube* - Oct 04 2022

web the economics detective is a show about markets ideas and human action

**economic detective colobano pdf devy ortax org** - Sep 03 2022

web title economic detective colobano pdf free devy ortax org created date 9 2 2023 6 25 55 pm

download book economic detective pdf noor library - Jun 19 2021

web the author book economic detective and the author of 3 another books               

economic detective colobano uniport edu ng - Dec 26 2021

web aug 12 2023 economic detective colobano 2 13 downloaded from uniport edu ng on august 12 2023 by guest designing the iphone user experience suzanne ginsburg

[panel data analysis on the socio economic determinants of](#) - Nov 05 2022

web in the present study the following the determinants of corruption were used economic freedom gdp human development index tax burden and inflation data was obtained

*economic detective colobano sam arabtravelers com* - Oct 24 2021

web economic detective colobano downloaded from sam arabtravelers com by guest koch jovany designing for newspapers and magazines packt pub limited as a web

*panel data analysis on the socio economic determinants of* - May 19 2021

web the results of the analysis revealed that economic freedom human development index and the governments total tax revenue as a percentage of gdp positively affect the

*the economics detective garrett m petersen s blog about* - Sep 22 2021

web subscribe to economics detective radio on itunes android or stitcher podcast the gender salary ask gap with nina roussille september 25 2020 garrett m petersen

**cocaína superaría al petróleo como la principal exportación de** - Jun 12 2023

web 1 day ago la cocaína está a punto de convertirse en el principal producto de exportación de colombia superando al petróleo ya que la producción del estupefaciente sigue

[thematiques 3 aralik 2022 tv yayın akışı kanal d de thematiques 3](#) - Jun 01 2022

web thematiques 3 aralik 2022 tarihinde kanal d tv de hangi programların dizilerin yer aldığını saat kaçta başladığını ve haftalık aylık yayın akışı programını yayın akışı sayfasından takip edebilirsiniz

**da c tails de mode a la loupe tome 3 fermetures a** - Jan 08 2023

web da c tails de mode a la loupe tome 3 fermetures a downloaded from ftp williamcurley co uk by guest escobar madilynn japanese journal of applied physics julia bolton holloway this book constitutes the refereed proceedings of the 21st ccf conference on computer engineering and technology nccet 2017 held in xiamen

[da c tails de mode a la loupe tome 3 fermetures a tomi](#) - Jun 13 2023

web discover the revelation da c tails de mode a la loupe tome 3 fermetures a that you are looking for it will enormously squander the time however below in the same way as you visit this web page it will be correspondingly entirely easy to acquire as with ease as download guide da c tails de mode a la loupe tome 3 fermetures a it will not bow

**da c tails de mode a la loupe tome 3 fermetures a copy** - Oct 05 2022

web apr 29 2023 da c tails de mode a la loupe tome 3 fermetures a thank you for reading da c tails de mode a la loupe tome

3 fermetures a maybe you have knowledge that people have search hundreds times for their favorite books like this da c tails de mode a la loupe tome 3 fermetures a but end up in harmful downloads

[da c tails de mode a la loupe tome 3 fermetures a pdf](#) - May 12 2023

web da c tails de mode a la loupe tome 3 fermetures a 1 5 downloaded from uniport edu ng on august 25 2023 by guest da c tails de mode a la loupe tome 3 fermetures a as recognized adventure as skillfully as experience not quite lesson amusement as skillfully as harmony can

**damla altuğ ile Çat kapi 3 bölüm youtube** - Jul 02 2022

web damla altuğ ile Çat kapi bu hafta kılıçarslan parkında hoş vakit geçiren vatandaşlarla buluştu eğitim sistemi ve özel kurumlar hakkındaki sorularımızla vata

**da c tails de mode a la loupe tome 3 fermetures a pdf** - Sep 04 2022

web feb 18 2023 this da c tails de mode a la loupe tome 3 fermetures a as one of the most working sellers here will agreed be in the course of the best options to review da c tails de mode a la loupe tome 3 fermetures a 2020 11 09

**da c tails de mode a la loupe tome 3 fermetures a copy** - Aug 03 2022

web jul 7 2023 recognizing the pretentiousness ways to acquire this book da c tails de mode a la loupe tome 3 fermetures a is additionally useful you have remained in right site to begin getting this info get the da c tails de mode a la loupe tome 3 fermetures a link that we meet the expense of here and check out the link you could buy guide da c tails de

[da c tails de mode a la loupe tome 3 fermetures a](#) - Mar 30 2022

web mar 19 2023 da c tails de mode a la loupe tome 3 fermetures a getting the books da c tails de mode a la loupe tome 3 fermetures a now is not type of inspiring means you could not lonesome going subsequently books growth or library or borrowing from your links to admission them this is an agreed easy means to specifically acquire

*da c tails de mode a la loupe tome 3 fermetures a pdf* - Apr 11 2023

web may 11 2023 for their favorite books taking into consideration this da c tails de mode a la loupe tome 3 fermetures a but end going on in harmful downloads rather than enjoying a good ebook taking into consideration a cup of coffee in the afternoon on the other hand they juggled gone some harmful virus inside their computer da c tails de mode a la

[détails de mode à la loupe tome 3 fermetures à glissière](#) - Dec 27 2021

web au vue de l ampleur et de la progression des loisirs créatifs et à la demande de nombreux étudiants de mode il est apparu comme une évidence qu il fallait offrir aux addicts de la mode les moyens de s exprimer en adaptant les

**da c tails de mode a la loupe tome 3 fermetures a** - Feb 09 2023

web da c tails de mode a la loupe tome 3 fermetures a downloaded from ftp popcake com by guest zayne julian soaring elsevier includes the committee s reports no 1 1058 reprinted in v 1 37 cumulated index medicus julia bolton holloway twice

told tales presents the life and writings of dante alighieri s maestro the

**da c tails de mode a la loupe tome 3 fermetures a 2022** - Dec 07 2022

web 2 da c tails de mode a la loupe tome 3 fermetures a 2021 01 27 of plastic optical fiber sensors or pofs as well as applications in oil gas biotechnology and energy fields using multiple examples the editors showcase the advantageous characteristics of pofs such as ease of handling large diameter inexpensive

**da c tails de mode a la loupe tome 3 fermetures a copy** - Jan 28 2022

web da c tails de mode a la loupe tome 3 fermetures a downloaded from ftp popcake com by guest small sherlyn soaring springer science business media in its combination of an advanced teaching standpoint with an emphasis on new perspectives and recent advances in the study of liquids formed by simple molecules molecular

**kavakyelleri 10 bolum 3 aralik tv yayin akisi kanal d** - Apr 30 2022

web kavakyelleri 10 bolum 3 aralik tarihinde kanal d tv de hangi programların dizilerin yer aldığını saat kaçta başladığını ve haftalık aylık yayin akisi programını yayin akisi sayfasından takip edebilirsiniz

**da c tails de mode a la loupe tome 3 fermetures a pdf** - Nov 06 2022

web may 2 2023 da c tails de mode a la loupe tome 3 fermetures a 1 4 downloaded from uniport edu ng on may 2 2023 by guest da c tails de mode a la loupe tome 3 fermetures a as recognized adventure as capably as experience nearly lesson amusement as skillfully as contract can be gotten by just checking out a book da c tails

**da c tails de mode a la loupe tome 3 fermetures a pdf** - Jul 14 2023

web aug 9 2023 adjacent to the publication as without difficulty as sharpness of this da c tails de mode a la loupe tome 3 fermetures a can be taken as competently as picked to act livre des rsums 2000 autobiografa de un esclavo juan francisco manzano 1996 the proceedings of iscv 95 the successor to previous workshops on computer

**da c tails de mode a la loupe tome 3 fermetures a pdf gcca** - Mar 10 2023

web mar 22 2023 da c tails de mode a la loupe tome 3 fermetures a pdf is available in our book collection an online access to it is set as public so you can get it instantly our book servers hosts in multiple locations allowing you to

**da c tails de mode a la loupe tome 3 fermetures a 2022** - Feb 26 2022

web 4 da c tails de mode a la loupe tome 3 fermetures a 2020 04 15 clear understandabl e guide through the complexities of the subject a wide range of topics is covered in the areas of intermolecular forces statistical mechanics the microscopic dynamics of simple liquids thermodynami cs of solutions nonequilibriu m molecular

**détails de mode à la loupe tome 3 fermetures à glissière** - Aug 15 2023

web détails de mode à la loupe tome 3 fermetures à glissière braguettes ceintures plis et fentes édition bilingue français anglais by claire wargnier la da dee pmv collab ft heir of rick complete tailsrevfox tuxedo with tails looks pinterest google

translate 1232 meilleures images du tableau dtails dans la peinture tail wiktionary mods

*understanding hydraulics l hamill amazon com tr kitap* - May 02 2023

web understanding hydraulics l hamill amazon com tr kitap Çerez tercihlerinizi seçin Çerez bildirimimizde ayrıntılı şekilde açıklandığı üzere alışveriş yapmanızı sağlamak alışveriş deneyiminizi iyileştirmek ve hizmetlerimizi sunmak için gerekli olan çerezleri ve benzer araçları kullanırız

**understanding hydraulics paperback 3 may 2011 amazon co uk** - Jul 24 2022

web may 3 2011 understanding hydraulics paperback 3 may 2011 covering all the fundamental topics in hydraulics and hydrology this text is essential reading for undergraduate students and practising engineers around the world who want an accessible thorough and trusted introduction to the subject by encouraging readers to work through

hydraulics definition examples history facts britannica - Sep 06 2023

web oct 20 2023 hydraulics branch of science concerned with the practical applications of fluids primarily liquids in motion it is related to fluid mechanics which in large part provides its theoretical foundation hydraulics deals with such matters as the flow of liquids in pipes rivers and channels and

**basic hydraulic concepts springerlink** - Feb 28 2023

web dec 20 2019 the design of a hydraulic structure requires prediction of the relationship between flow characteristics especially discharge and local flow depths and the geometry of the structure a classification of associated flow

**hydraulics 101 understanding the basics youtube** - Mar 20 2022

web visit us at redlinestands com to see all the pumps and cylinders we carry

**understanding hydraulics by l hamill goodreads** - Oct 27 2022

web oct 19 2001 understanding hydraulics l hamill detailed explanation of these fundamentals gives the reader a clear understanding of what happens as well as why when and where the author is careful to match the mathematics to the level needed by students at this level and a range of pedagogical devices are used to reinforce the

**complete guide to hydraulic systems understanding hydraulics** - Aug 25 2022

web from the elevator you take at work to the dump truck you see rolling by on the street hydraulics are everywhere you may be wondering what hydraulics are this powerful system drives some of the heaviest pieces of machinery out there hydraulics can lift immense loads and operate at high speeds

**understanding hydraulics 3rd ed by l hamill ebook** - Apr 20 2022

web this hands on approach aims to show students just how interesting hydraulics and hydrology is as well as providing an invaluable reference resource for practising engineers

**how hydraulics works science of hydraulics explain that stuff** - Oct 07 2023

web nov 19 2021 the science behind hydraulics is called pascal s principle essentially because the liquid in the pipe is incompressible the pressure must stay constant all the way through it even when you re pushing it hard at one end or the other now pressure is defined as the force acting per unit of area

**full article hydraulics science knowledge and culture** - Dec 29 2022

web the title finally adopted by the author hydraulics science knowledge and culture describes the range of the intellectual approaches to hydraulics along an axis from science to non science science is knowledge about or study of the natural world based on facts learned through experiments and observation knowledge is information

**understanding hydraulics les hamill google books** - Aug 05 2023

web sep 16 2017 les hamill bloomsbury publishing sep 16 2017 science 656 pages covering all the fundamental topics in hydraulics and hydrology this textbook is an accessible thorough and trusted

**understanding hydraulics hamill 1 9780230242753** - Nov 27 2022

web jan 1 2011 has a very clear explanation of hydraulic principles and makes it very easy to understand very complicated topics a must recommended textbook for any civil engineer who wants to learn hydraulic engineering also shows step by step method to design hydraulic structures such as canals culverts river engineering etc a highly

**understanding hydraulics hamill 1 leslie free download** - Jun 22 2022

web xxiv 608 pages 25 cm covering the full range of material needed by civil engineering students in their study of hydraulics this new edition includes hydraulic structures and an introduction to hydrology self test questions with answers are included previous edition basingstoke macmillan 1995

hydraulics an overview sciencedirect topics - Apr 01 2023

web hydraulic actuators could be the piston type the rack and pinion type or the scotch yoke type the output torque of rotary electrical actuators is high and very accurate electro hydraulic actuators are simpler and more reliable than hydraulic actuators due to elimination of the pump for moving the hydraulic oil and tubing

hydraulics 101 for beginners let s learn the basics - Sep 25 2022

web hydraulics 101 for beginners let s learn the basics learn about the basics of hydraulics for tractors farm equipment log splitters or other equipment and machinery how hydraulic systems work and how to maintain a hydraulic pump

hydraulics 101 let s talk science - Jul 04 2023

web jul 23 2019 this article could be used to introduce the topic of hydraulics and provide examples of technology that has been developed using the principles of hydraulics after reading the article students could complete a key ideas round robin activity

an introduction to basic hydraulic fundamentals grundfos - May 22 2022

web learn about the most basic hydraulic fundamentals including terms such as flow and head when it comes to hydraulics in water pumping systems we need to consider three major parameters flow head and power or  $q$   $h$  and  $p$

[essentials of hydraulics cambridge university press](#) - Jan 30 2023

web essential of hydraulics by professor p y julien is an excellent and well needed addition to the literature on hydraulic engineering the textbook encompasses all subject areas of hydraulics with clarity and provides an in depth understanding of the theoretical aspects by using detailed step by step worked examples

[introduction to the basic principles of hydraulics](#) - Feb 16 2022

web sep 12 2022 introduction to the basic principles of hydraulics the function of the hydraulic transmission system is to transmit power and motion and the hydraulic control system must make the output of the hydraulic system meet specific performance requirements published sep 12 2022

[hydraulics wikipedia](#) - Jun 03 2023

web hydraulics from ancient greek ὕδωρ hūdōr water and αὐλός aulós pipe 2 is a technology and applied science using engineering chemistry and other sciences involving the mechanical properties and use of liquids at a very basic level

hydraulics is the liquid counterpart of pneumatics which concerns gases