

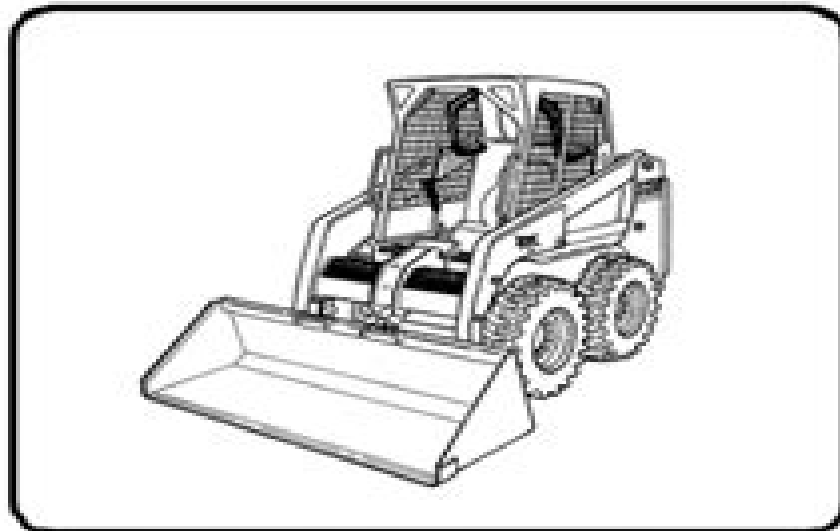

Bobcat.

Service Manual S130 Skid-Steer Loader

S/N A3KY20001 & Above



EQUIPPED WITH
BOBCAT INTERLOCK
CONTROL SYSTEM (BICS™)

Illustration: 311-100

Printed in U.S.A. © Bobcat Company 2010

JoeManual.com

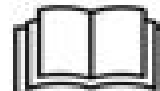

Remove the stop button (1) from the lever (2).



Remove the stop button (1) from the lever (2).



Remove the stop button (1) from the lever (2) to allow the lever to be moved.



Remove the stop button (1) from the lever (2).



Remove the stop button (1) from the lever (2) to allow the lever to be moved.



Remove the stop button (1) from the lever (2).

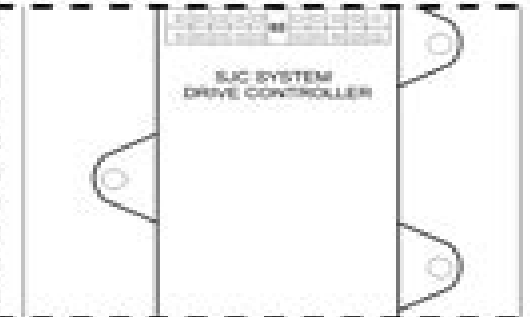

Remove the stop button (1) from the lever (2).



Remove the stop button (1) from the lever (2) to allow the lever to be moved.

WARNING

Always use proper lifting techniques. Do not lift or carry loads that are too heavy or awkward, or that require twisting or reaching in any direction. Do not use the loader to lift or carry loads that are not designed for this purpose.

Always use proper lifting techniques. Do not lift or carry loads that are too heavy or awkward, or that require twisting or reaching in any direction. Do not use the loader to lift or carry loads that are not designed for this purpose.

Always use proper lifting techniques. Do not lift or carry loads that are too heavy or awkward, or that require twisting or reaching in any direction. Do not use the loader to lift or carry loads that are not designed for this purpose.

Bobcat S130 Service Manual

Lingjun Ying



Bobcat S130 Service Manual:

Backpacker ,2004-03 Backpacker brings the outdoors straight to the reader s doorstep inspiring and enabling them to go more places and enjoy nature more often The authority on active adventure Backpacker is the world s first GPS enabled magazine and the only magazine whose editors personally test the hiking trails camping gear and survival tips they publish Backpacker s Editors Choice Awards an industry honor recognizing design feature and product innovation has become the gold standard against which all other outdoor industry awards are measured *Bobcat 641, 642, 643* Clark Equipment Company. Clark Melroe Division,1981 **843 Service Manual** Clark Equipment Company. Melroe Division,1982 Clark 700 Series Heavy Duty Bobcat Service Manual ,1982* **Bobcat 453 (SN 515011001 & Up) Service Manual** Melroe/Ingersoll-Rand,1997 *Melroe Bobcat Service Manual* Clark Equipment Company. Melroe Division,1972 *Bobcat 741, 742, 742B, 743, 743B, 743DS Service Manual* ,1992* **Evinrude Bobcat SS Service Manual** Outboard Marine Corporation. Evinrude Motors Division,1971 **Evinrude Bobcat Service Manual** Outboard Marine Corporation. Evinrude Motors Division,1970 *Haynes Ford Pinto and (Mercury Bobcat) Manual No. 649* John Haynes,1983-02-06 Haynes disassembles every subject vehicle and documents every step with through instructions and clear photos Haynes repair manuals are used by the pros but written for the do it yourselfer *Service Manual* Caterpillar Tractor Company (U.S.A),1983 *Service Manual* Diamond T Motor Car Company. Service Dept,1948 *Service Manual International 100 and 125 Loaders, SM-27* ,1967 **Service Manual** ,1970 **Ford Pinto & Mercury Bobcat Owners Workshop Manual** P. G. Strasman, Service Repair Manual David Brown Tractors Ltd,1979 **Operator and Organizational Maintenance Manual** ,1982 *Service Manual* ,1968 **1959 to 1966 Bobcat Pacer-Scat Super-10 Model 165 Hummer Service Manual** Harley-Davidson Motor Company, *Service Manual; Tractors, Transmissions, Engines, Hydraulic Systems* Oliver Corporation,1970

Embark on a transformative journey with its captivating work, Grab Your Copy of **Bobcat S130 Service Manual** . This enlightening ebook, available for download in a convenient PDF format , invites you to explore a world of boundless knowledge. Unleash your intellectual curiosity and discover the power of words as you dive into this riveting creation. Download now and elevate your reading experience to new heights .

https://recruitmentslovakia.com/About/Resources/fetch.php/User_Manual_Sylvania_Telephone.pdf

Table of Contents Bobcat S130 Service Manual

1. Understanding the eBook Bobcat S130 Service Manual
 - The Rise of Digital Reading Bobcat S130 Service Manual
 - Advantages of eBooks Over Traditional Books
2. Identifying Bobcat S130 Service Manual
 - Exploring Different Genres
 - Considering Fiction vs. Non-Fiction
 - Determining Your Reading Goals
3. Choosing the Right eBook Platform
 - Popular eBook Platforms
 - Features to Look for in an Bobcat S130 Service Manual
 - User-Friendly Interface
4. Exploring eBook Recommendations from Bobcat S130 Service Manual
 - Personalized Recommendations
 - Bobcat S130 Service Manual User Reviews and Ratings
 - Bobcat S130 Service Manual and Bestseller Lists
5. Accessing Bobcat S130 Service Manual Free and Paid eBooks
 - Bobcat S130 Service Manual Public Domain eBooks
 - Bobcat S130 Service Manual eBook Subscription Services
 - Bobcat S130 Service Manual Budget-Friendly Options

6. Navigating Bobcat S130 Service Manual eBook Formats
 - ePub, PDF, MOBI, and More
 - Bobcat S130 Service Manual Compatibility with Devices
 - Bobcat S130 Service Manual Enhanced eBook Features
7. Enhancing Your Reading Experience
 - Adjustable Fonts and Text Sizes of Bobcat S130 Service Manual
 - Highlighting and Note-Taking Bobcat S130 Service Manual
 - Interactive Elements Bobcat S130 Service Manual
8. Staying Engaged with Bobcat S130 Service Manual
 - Joining Online Reading Communities
 - Participating in Virtual Book Clubs
 - Following Authors and Publishers Bobcat S130 Service Manual
9. Balancing eBooks and Physical Books Bobcat S130 Service Manual
 - Benefits of a Digital Library
 - Creating a Diverse Reading Collection Bobcat S130 Service Manual
10. Overcoming Reading Challenges
 - Dealing with Digital Eye Strain
 - Minimizing Distractions
 - Managing Screen Time
11. Cultivating a Reading Routine Bobcat S130 Service Manual
 - Setting Reading Goals Bobcat S130 Service Manual
 - Carving Out Dedicated Reading Time
12. Sourcing Reliable Information of Bobcat S130 Service Manual
 - Fact-Checking eBook Content of Bobcat S130 Service Manual
 - Distinguishing Credible Sources
13. Promoting Lifelong Learning
 - Utilizing eBooks for Skill Development
 - Exploring Educational eBooks
14. Embracing eBook Trends
 - Integration of Multimedia Elements

- Interactive and Gamified eBooks

Bobcat S130 Service Manual Introduction

Bobcat S130 Service Manual Offers over 60,000 free eBooks, including many classics that are in the public domain. Open Library: Provides access to over 1 million free eBooks, including classic literature and contemporary works. Bobcat S130 Service Manual Offers a vast collection of books, some of which are available for free as PDF downloads, particularly older books in the public domain. Bobcat S130 Service Manual : This website hosts a vast collection of scientific articles, books, and textbooks. While it operates in a legal gray area due to copyright issues, its a popular resource for finding various publications. Internet Archive for Bobcat S130 Service Manual : Has an extensive collection of digital content, including books, articles, videos, and more. It has a massive library of free downloadable books. Free-eBooks Bobcat S130 Service Manual Offers a diverse range of free eBooks across various genres. Bobcat S130 Service Manual Focuses mainly on educational books, textbooks, and business books. It offers free PDF downloads for educational purposes. Bobcat S130 Service Manual Provides a large selection of free eBooks in different genres, which are available for download in various formats, including PDF. Finding specific Bobcat S130 Service Manual, especially related to Bobcat S130 Service Manual, might be challenging as theyre often artistic creations rather than practical blueprints. However, you can explore the following steps to search for or create your own Online Searches: Look for websites, forums, or blogs dedicated to Bobcat S130 Service Manual, Sometimes enthusiasts share their designs or concepts in PDF format. Books and Magazines Some Bobcat S130 Service Manual books or magazines might include. Look for these in online stores or libraries. Remember that while Bobcat S130 Service Manual, sharing copyrighted material without permission is not legal. Always ensure youre either creating your own or obtaining them from legitimate sources that allow sharing and downloading. Library Check if your local library offers eBook lending services. Many libraries have digital catalogs where you can borrow Bobcat S130 Service Manual eBooks for free, including popular titles. Online Retailers: Websites like Amazon, Google Books, or Apple Books often sell eBooks. Sometimes, authors or publishers offer promotions or free periods for certain books. Authors Website Occasionally, authors provide excerpts or short stories for free on their websites. While this might not be the Bobcat S130 Service Manual full book , it can give you a taste of the authors writing style. Subscription Services Platforms like Kindle Unlimited or Scribd offer subscription-based access to a wide range of Bobcat S130 Service Manual eBooks, including some popular titles.

FAQs About Bobcat S130 Service Manual Books

1. Where can I buy Bobcat S130 Service Manual books? Bookstores: Physical bookstores like Barnes & Noble, Waterstones, and independent local stores. Online Retailers: Amazon, Book Depository, and various online bookstores offer a wide range of books in physical and digital formats.
2. What are the different book formats available? Hardcover: Sturdy and durable, usually more expensive. Paperback: Cheaper, lighter, and more portable than hardcovers. E-books: Digital books available for e-readers like Kindle or software like Apple Books, Kindle, and Google Play Books.
3. How do I choose a Bobcat S130 Service Manual book to read? Genres: Consider the genre you enjoy (fiction, non-fiction, mystery, sci-fi, etc.). Recommendations: Ask friends, join book clubs, or explore online reviews and recommendations. Author: If you like a particular author, you might enjoy more of their work.
4. How do I take care of Bobcat S130 Service Manual books? Storage: Keep them away from direct sunlight and in a dry environment. Handling: Avoid folding pages, use bookmarks, and handle them with clean hands. Cleaning: Gently dust the covers and pages occasionally.
5. Can I borrow books without buying them? Public Libraries: Local libraries offer a wide range of books for borrowing. Book Swaps: Community book exchanges or online platforms where people exchange books.
6. How can I track my reading progress or manage my book collection? Book Tracking Apps: Goodreads, LibraryThing, and Book Catalogue are popular apps for tracking your reading progress and managing book collections. Spreadsheets: You can create your own spreadsheet to track books read, ratings, and other details.
7. What are Bobcat S130 Service Manual audiobooks, and where can I find them? Audiobooks: Audio recordings of books, perfect for listening while commuting or multitasking. Platforms: Audible, LibriVox, and Google Play Books offer a wide selection of audiobooks.
8. How do I support authors or the book industry? Buy Books: Purchase books from authors or independent bookstores. Reviews: Leave reviews on platforms like Goodreads or Amazon. Promotion: Share your favorite books on social media or recommend them to friends.
9. Are there book clubs or reading communities I can join? Local Clubs: Check for local book clubs in libraries or community centers. Online Communities: Platforms like Goodreads have virtual book clubs and discussion groups.
10. Can I read Bobcat S130 Service Manual books for free? Public Domain Books: Many classic books are available for free as they're in the public domain. Free E-books: Some websites offer free e-books legally, like Project Gutenberg or Open Library.

Find Bobcat S130 Service Manual :

[user manual sylvania telephone](#)

[2006 acura tl egr valve manual](#)

[advanced problems in organic chemistry by himanshu pandey](#)

[year 5 optional sats 1998 maths mark scheme](#)

[stand tall study guide](#)

onity edht22i locks manual

[bmw airbag fault code](#)

[onity ht24 manual](#)

[walther ppks 380 owners manual](#)

[interests and obsessions historical essays](#)

sella ronda selva snow report

2nd semester biology semester test study guide

[multiple choice quiz questions on first aid](#)

1999 2000 buell lightning x1 service repair manual 99 00

novel stars geography answer key

Bobcat S130 Service Manual :

2021 Ford E-450 Owner Manuals Find your Ford Owner Manual here. Print, read or download a PDF or browse an easy, online, clickable version. Access quick reference guides, ... 2021 E-SERIES Owner's Manual - IIS Windows Server E-450 Cutaway. Maximum. GCWR. Rear Axle. Ratio. Wheelbase. Length. Rear Axle. Option ... This owner's manual and the Ford. Workshop Manual list the recommended. User manual Ford E-450 (2021) (English - 301 pages) Manual. View the manual for the Ford E-450 (2021) here, for free. This manual comes under the category cars and has been rated by 1 people with an average ... 2019 E-SERIES Owner's Manual - IIS Windows Server E-450 Cutaway. Maximum. GCWR. Rear Axle. Ratio. Wheelbase. Length. Rear Axle. Option ... This owner's manual and the Ford. Workshop Manual list the recommended. Repair Manuals & Literature for Ford E-450 Super Duty Get the best deals on Repair Manuals & Literature for Ford E-450 Super Duty when you shop the largest online selection at eBay.com. 2019 Ford E450 Cutaway Van Owner Manual User Guide ... 2019 Ford E450 Cutaway Van Owner Manual User Guide Set DRW 6.8L Triton V10 New ; ISBN. Does not apply ; Accurate description. 4.8 ; Reasonable shipping cost. 5.0. Coachmen RV Ford E450 Manual View and Download Coachmen RV Ford

E450 manual online. 2007 Coachman Freeland 31. Ford E450 motorhomes pdf manual download. Need repair manual for E-450 - help? Jan 14, 2013 — 1968-Present E-Series Van/Cutaway/Chassis - Need repair manual for E-450 - help? - Looking around the net for a Haynes or Chiltons manual ... OEM Service manuals for 2005 Ford E450 Chassis I would like to know where complete factory service manuals can be obtained. I would like the complete set that includes: Chassis, Electrical, Engine, ... Ford E450 F550 Owners Manual1445586157100 | PDF CAUTION! Back-up Pump Lift Control YOU MUST READ AND UNDERSTAND THE MANUFACTURERS Pump Handle OPERATORS MANUAL BEFORE EVER OPERATING THIS LIFT Release Valve. Portuguese For Dummies by Keller, Karen Portuguese for Dummies, of course! This fun, friendly guide helps you start speaking Brazilian Portuguese immediately! Whether you're a student, a traveler, or ... Portuguese For Dummies by Keller, Karen Portuguese for Dummies is a well-written beginner's text for the study of that language or at least the Brazilian version of that language. Karen Keller is ... Portuguese For Dummies Cheat Sheet Feb 22, 2022 — This article can be found in the category: Portuguese . From the Book Brazilian Portuguese For Dummies. Brazilian Portuguese For Dummies Brazilian Portuguese For Dummies, 3rd Edition (1119894654) is your easy-to-follow guide to the language, for travel, school, or just fun! Portuguese Books Portuguese Phrases for Dummies is the perfect diving board for anyone looking to communicate and even become fluent in the language. As the fifth-most widely ... Portuguese Phrases For Dummies Want to improve your conversation skills with the Portuguese-speaking people in your life? Portuguese Phrases for Dummies is the perfect diving board for anyone ... Brazilian Portuguese for Dummies (Paperback) Aug 2, 2022 — Brazilian Portuguese For Dummies can help you achieve your goals of learning another language. Traveling to Brazil? Taking a class in school? Brazilian Portuguese For Dummies, 3rd Edition Language learning is easy with Dummies Brazilian Portuguese For Dummies can help you achieve your goals of learning another language. Traveling to Brazil? Portuguese For Dummies by Karen Keller, Paperback Portuguese For Dummies · Paperback · \$24.99. Portuguese for Dummies book by Karen Keller Buy a cheap copy of Portuguese for Dummies book by Karen Keller. Quick What's the most widely spoken language in South America? That's right, Portuguese And ... CA Branch 3 Practice Test Flashcards CA Branch 3 Practice Test. 4.2 (6 reviews). Flashcards · Learn · Test · Match ... Field Rep (SPCB) -- SAFETY/REGULATORY. 169 terms. Profile Picture. CA BRANCH 3 Structural Pest Control Flashcards To obtain a field representative license in Branch 3, the applicant must prove that he/she has had training and experience in the following areas. Pest ... branch 3 field rep study material This course is a study guide for Branch 3 California Field Reps to pass their state test. Field Representative test. Pest Control Courses from Pested.com. Examinations - Structural Pest Control Board - CA.gov Field Representative Branch 3 Candidate Handbook. Field Representative examination ... Field Representative License along with their examination results. The ... Branch 3 Field Rep Practice Test ... Practice Test. What is medicine? Definition, fields, and branches - Medical News Today. COVID-19: determining materiality - economica. Detroit Lions vs. Pest Control Chronicles: I Pass My Branch 3 Field Rep Exam ... Branch 3 field rep practice test -

resp.app As recognized, adventure as capably as experience virtually lesson, amusement, as without difficulty as pact can be gotten by just checking out a ebook ... Branch 3 field rep practice test - resp.app Aug 15, 2023 — It is your totally branch 3 field rep practice test own era to measure reviewing habit. in the middle of guides you could enjoy now is ... Operator Branch 3 Examination Resources PCT Technician's Handbook: A Guide to Pest Identification and Management (4th Ed.) Kramer, R. GIE Media - (800) 456-0707. NPCA Field Guide to Structural Pests. Branch 3 license Study Guide Study and prepare for the Branch 3 license exam with this prep class. Includes Branch 3 license study guide and breakfast. Get the necessary tools to obtain ...